

ART. 3017

Fascette stringitubo DIN 3017 W4 - h. 9 mm , aisi 304 / A2

Hose clamps DIN 3017 W4 - h. 9 mm, aisi 304 / A2



Codice Articolo Item Number	Ø (mm)	Box	Master carton	Pallet
3017-2-8*16/9	08 - 16	100	800	28800
3017-2-12*20/9	12 - 20	100	800	28800
3017-2-12*22/9	12 - 22	100	800	28800
3017-2-16*25/9	16 - 25	50	400	14400
3017-2-20*32/9	20 - 32	50	250	9000
3017-2-25*40/9	25 - 40	50	200	7200
3017-2-32*50/9	32 - 50	50	150	5400
3017-2-40*60/9	40 - 60	25	100	3600
3017-2-50*70/9	50 - 70	25	100	3600

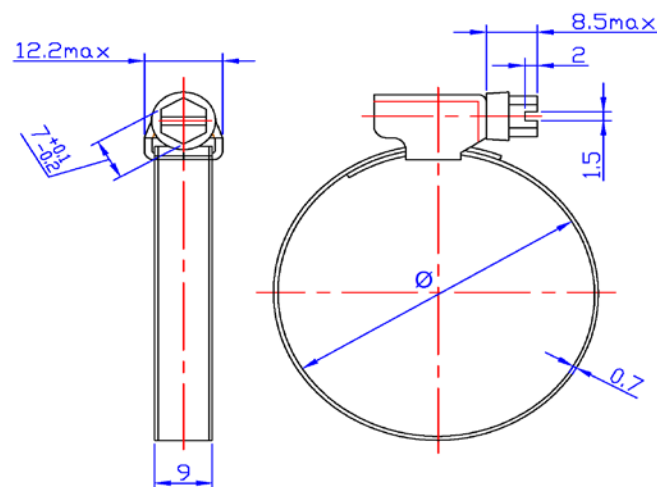

Banda con bordo rialzato e superficie interna piana, per evitare danneggiamenti al tubo.

Viti in acciaio inossidabile, sottoposte ad un ulteriore trattamento di zincatura (CR+3), per evitare il fenomeno del "Grippaggio"

With edge raised band and plani inner surface to avoid damages at the hose.

Stainless Steel screws, submitted to a further galvanizing treatment (zinc plated CR+3) in order to avoid "Seizing"

last edit 19/02/2019

DRAWING N. 1021